

Pacific Performance Engineering, Inc.
www.ppediesel.com

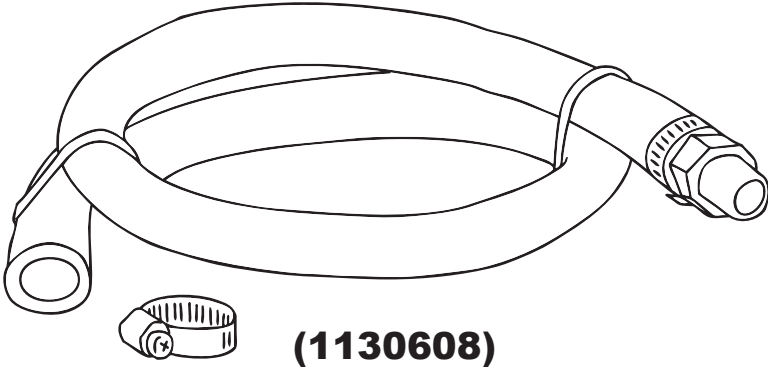

(1130608)
CP3 Pump Fuel Feed Line Kit
without inlet fitting

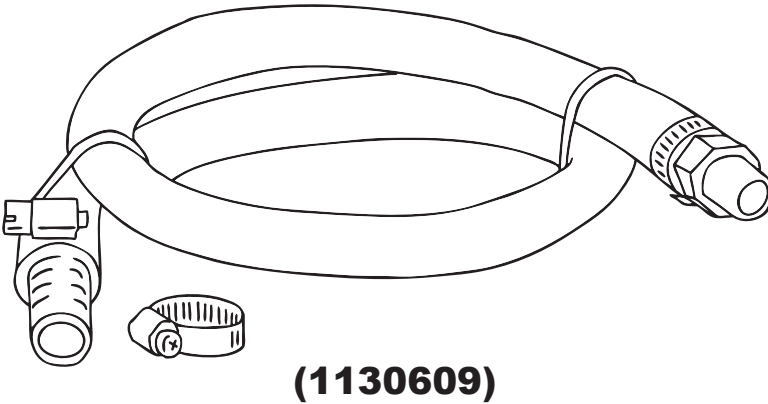

(1130609)
CP3 Pump Fuel Feed Line Kit
with inlet fitting

Installation Guide

DISCLAIMER OF LIABILITY

This is a performance product which is used with increased horsepower above factory specifications. Additional horsepower creates more stress on your vehicle's drivetrain components which may result in drivetrain failure. This product is intended for off-road use only. Use at your own risk!

This agreement sets forth the terms and conditions for the use of this product. The installation of this product indicates that the Buyer has read and understands this agreement and accepts the terms and conditions.

Pacific Performance Engineering Inc., its distributors, employees, and dealers (the "Seller") shall not be responsible for this product's improper use and service. The Buyer hereby waives all liability claims.

The Buyer hereby acknowledges no reliance on the Seller's skill or judgment to select or furnish goods suitable for any particular purpose and that there are no liabilities which extend beyond the description on the face hereof, and the Buyer hereby waives all remedies or liabilities expressed or implied, arising by law or otherwise (including without any obligation of the Seller with respect to fitness, merchantability and consequential damages), or whether or not occasioned by the Seller's negligence.

The Seller disclaims any warranty and expressly disclaims any liability for personal injury or damages. The Buyer acknowledges and agrees that the disclaimer of any liability for personal injury is a material term for this agreement and the Buyer agrees to indemnify the Seller and to hold the Seller harmless from any claim related to the item of equipment purchased. Under no circumstances will the Seller be liable for any damages or expenses by reason of use or sale of any such equipment.

The Seller assumes no liability regarding the improper installation or misapplication of its products. It is the installer's responsibility to check for proper installation and if in doubt, contact the manufacturer.

The Buyer is solely responsible for all warranty issues from the manufacturer.

LIMITATION OF WARRANTY

The Seller gives Limited Warranty as to description, quality, merchantability, and fitness for a particular purpose, productiveness, or any other matter of Seller's product sold herewith. The Seller shall not be responsible for the products proper use and service and the Buyer hereby waives all rights other than those expressly written herein. This warranty shall not be extended, altered or varied except by a written instrument signed by Seller and Buyer.

The Warranty is limited to one (1) year from the date of sale and limited solely to the parts contained within the products kit. All products that are in question of Warranty must be returned prepaid to the Seller and must be accompanied by a dated proof of purchase receipt. All Warranty claims are subject to approval by Seller.

Under no circumstances will the Seller be liable for any labor charged or travel time incurred in diagnosis for defects, removal, or reinstallation of this product or any other contingent expenses.

Under no circumstances will the Seller be liable for any damage or expenses incurred by reason of the use or sale of any such equipment.

In the event that the Buyer does not agree with this agreement; the Buyer may promptly return this product, in a new and unused condition in its original packaging, with a dated proof of purchase to the place of purchase within ten (10) days from date of purchase for a full refund.

The installation of this product indicates that the Buyer has read and understands this agreement and accepts its terms and conditions.

- 1) Remove the fan belt.
- 2) Remove the A/C compressor bolts.
- 3) Lift and move the A/C compressor up and over to clear the way for access to the CP3 injection pump.
- 4) No need to remove the A/C lines, they are flexible enough to follow the A/C compressor.
- 5) Once you have access to the CP3 pump, change out the inlet fitting. Inlet fitting included in kit #1130609.
- 6) Run the fuel line over to the fuel filter housing.
- 7) Now the fuel line that comes out of the fuel filter housing is 1/2" ID. We need this line to connect up to the feed line kit. This line will be left connected to the fuel filter housing, but the end that is connected over by the alternator will be removed and connected to the 1/2" barbed connector on the high flow feed line kit. So the fuel will now flow from the fuel filter housing through the 1/2" line, through the 1/2 to 3/8 reducer, through the 3/8" line, to the high flow CP3 inlet fitting.
- 8) All that is left is to reinstall the A/C compressor and bolts.
- 9) Install the fan belt.



PACIFIC PERFORMANCE ENGINEERING

Pacific Performance Engineering, Inc.
303 N. Placentia Avenue
Fullerton, CA 92831

www.ppediesel.com
sales@ppediesel.com
Phone: (714) 985-4825
Fax: (714) 985-9907